

```

0001 PROGRAM PLC_PRG
0002 VAR
0003     Bewegungsablauf_1:Spindelfunktion;
0004     Bewegungsablauf_2:Spindelfunktion;
0005     Bewegungsablauf_3:Spindelfunktion;
0006
0007 END_VAR

```

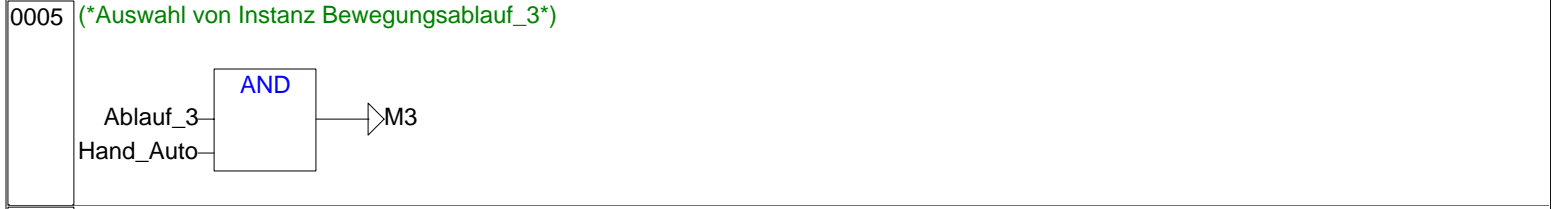
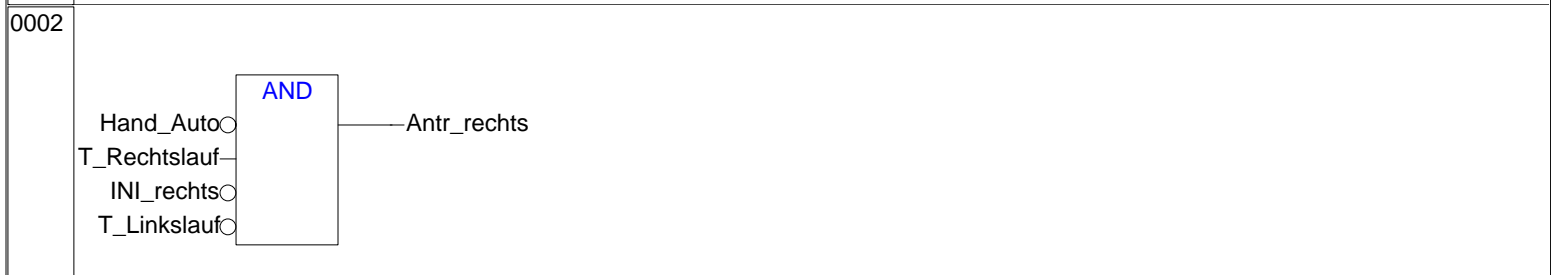
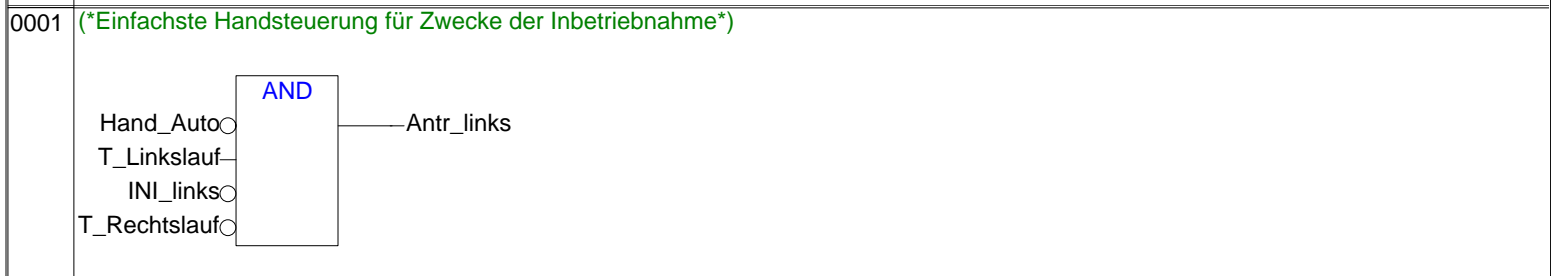

0006

```

TRUE—<Return>

```

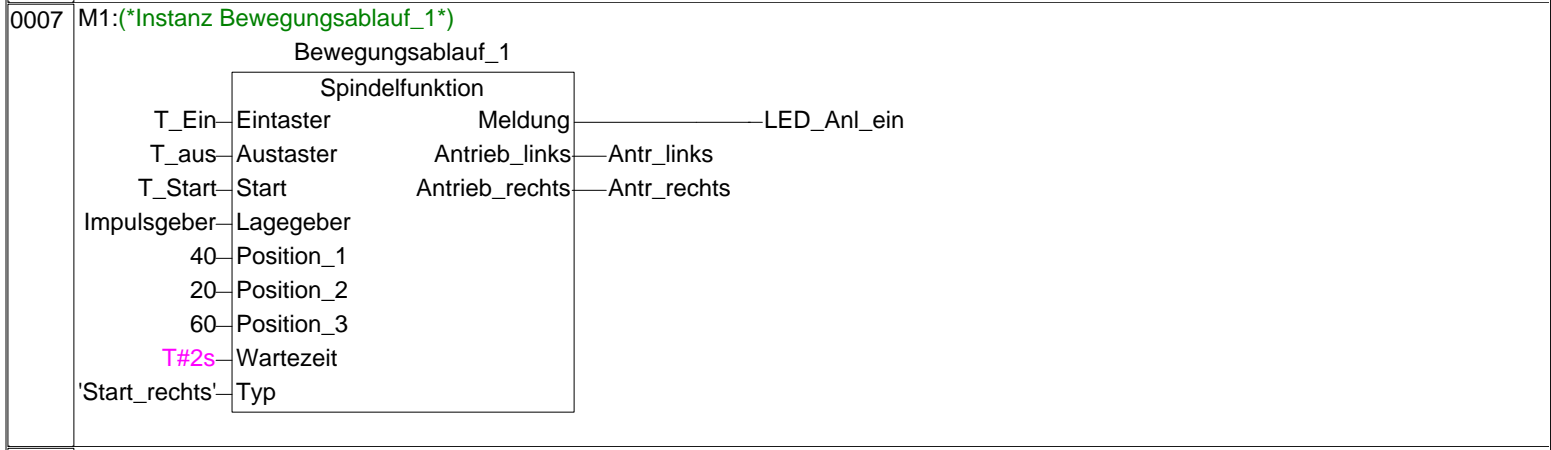

0008

```

TRUE—<Return>

```

